



Technic Lego®

8258 Crane Truck

Modification Package



Copyright modifications: Han Crielaard

2009

www.designer-han.nl/lego

These building instructions are 'free to use' for every Lego® fan and may not commercially be used and/or sold

LEGO® is a trademark of the LEGO Group of companies which does not sponsor, authorize or endorse these building instructions

Description of modification package

General information

- With the release of this Crane Truck, the Lego Company shows – today – one of the most appealing Technic Lego sets. Especially the exterior of truck and the very realistic operating crane arm.
- However, to my opinion the set needs some **small and easy to apply** improvements which I like to share. Applying these changes will definitely increase the playability of this fantastic model.

Modifications

- The modifications are categorized into 3 area's:
 - **CRITICAL**: many customers noticed that the original set sometimes 'crunches' the 12th tooth bevel gear nearby the XL motor drive-shaft. This can be solved by applying **ALL** these critical modifications.
 - **IMPROVED PLAYABILITY**: modifications who will contribute to a more effective usage of the technic functions.
 - **APPEARANCE**: only 'cosmetic' modifications.

Mod. #	Type	Description
1	Critical	Add 24 th tooth clutch-gear on 1 st crane arm section
2	Critical	Relocation of the 24 th tooth clutch-gear of the 2 nd crane arm section
3	Critical	Prevent 'walking axles' for each 12 th tooth bevel gear within each PF-LA bracket
4	Improved playability	Reverse movement of the outriggers; to avoid a motor direction switch
5	Improved playability	Extra clarification to assure precisely 'in-line' steering of 1 st and 2 nd wheels
6	Improved playability	Correction of lifting eye of extendable crane arm
7	Appearance	Correction of last wheel axle length
8	Appearance	Apply short axles (3L) to the steered wheels



Critical modifications:

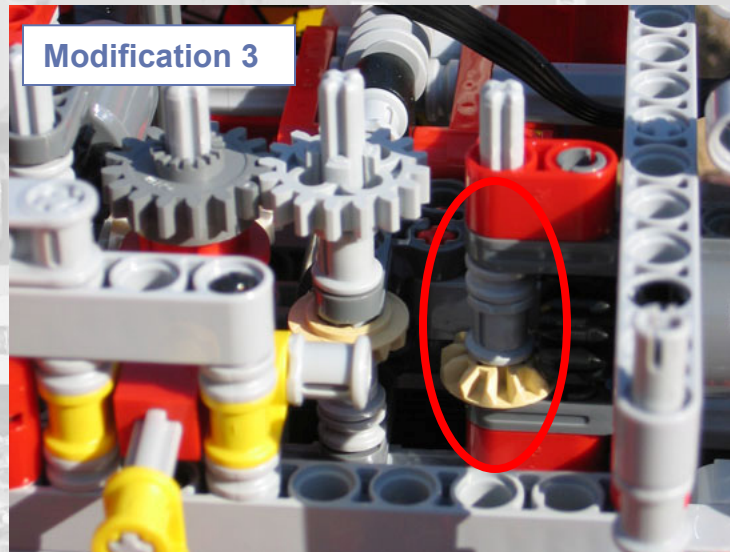
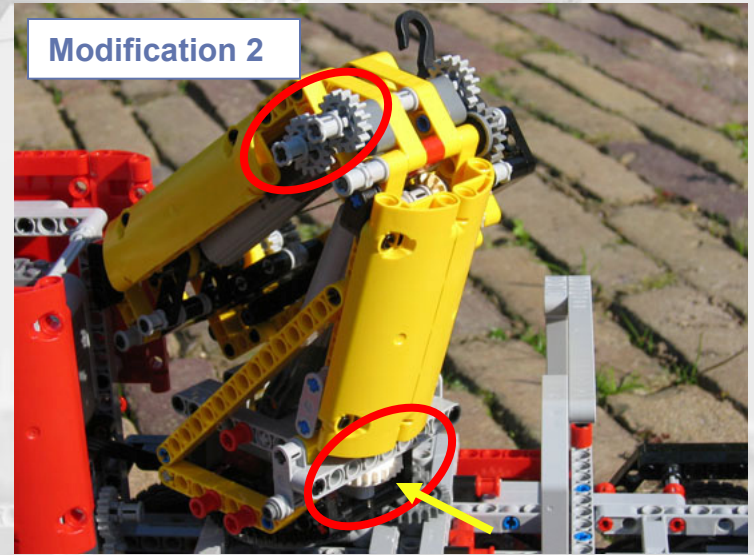
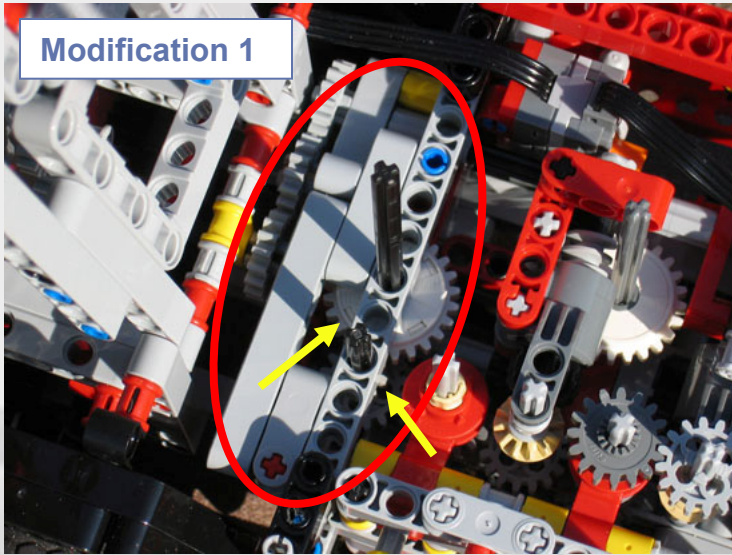

Mod-1: Add 24th clutch-gear on 1st crane arm section (1)

Original (step 35)

This modification does consists of 3 separate changes:
a) book-1, page 40, step 35
b) book-1, page 42 & 43, step 37 & 38
c) book-1, page 83, step 22

Modification: Book-1, page 40, replace completely step 35 with:

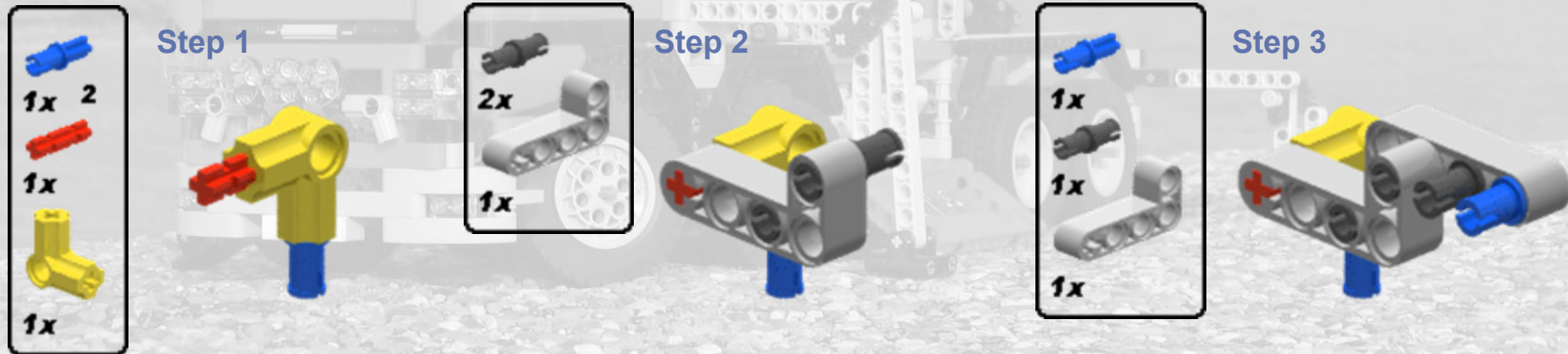

Mod-1: Add 24th clutch-gear on 1st crane arm section (2)

Step 4

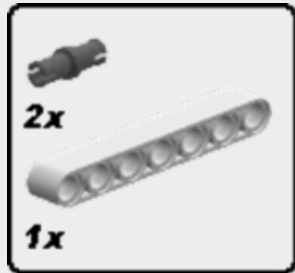

Step 5

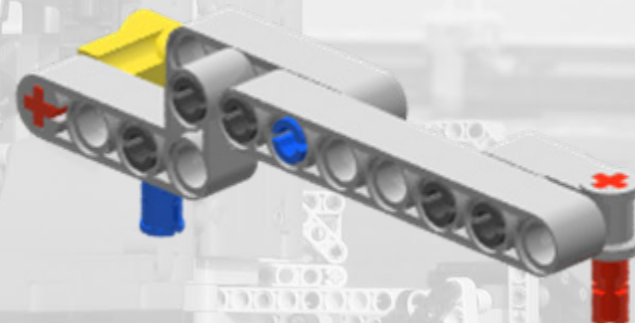

Last step 6

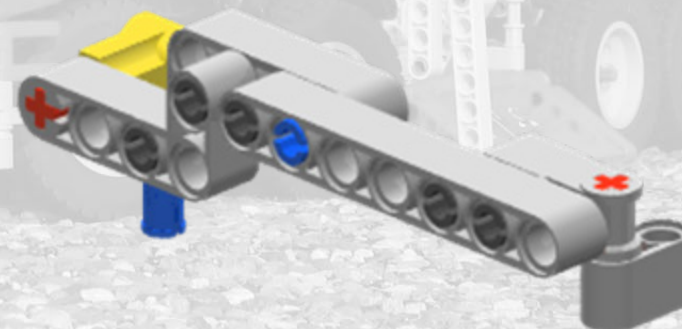

Mod-1: Add 24th clutch-gear on 1st crane arm section (3)

Modification: Book-1, page 42 & 43, replace:

Step 37 with:

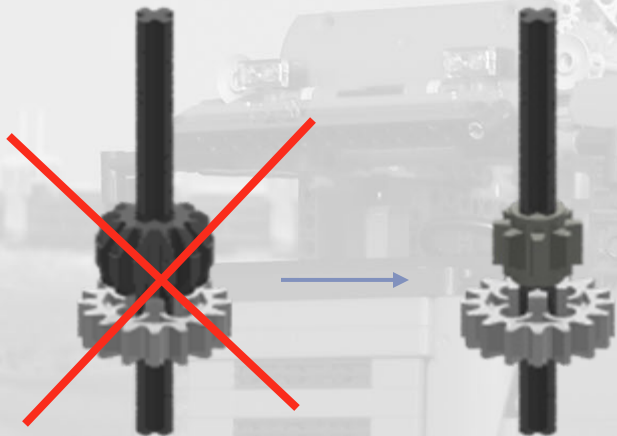

Replace 12th tooth double bevel gear with 8th tooth gear

Step 38 with:

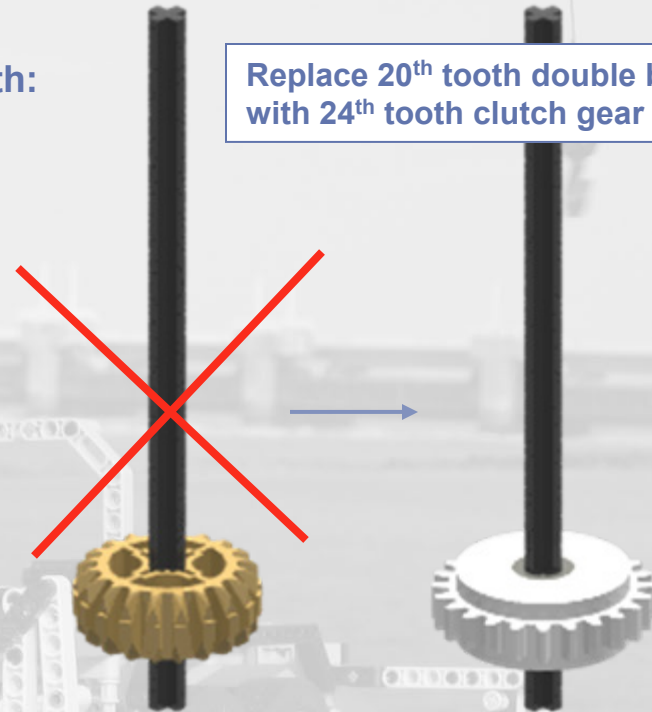

Replace 20th tooth double bevel gear with 24th tooth clutch gear

Modification: Book-1, page 83, replace step 22 with:

Replace axle 5 with axle 4 + bush



Mod-2: Relocation 24th clutch gear on 2nd crane arm section (1)

Original (step 1 to 9)

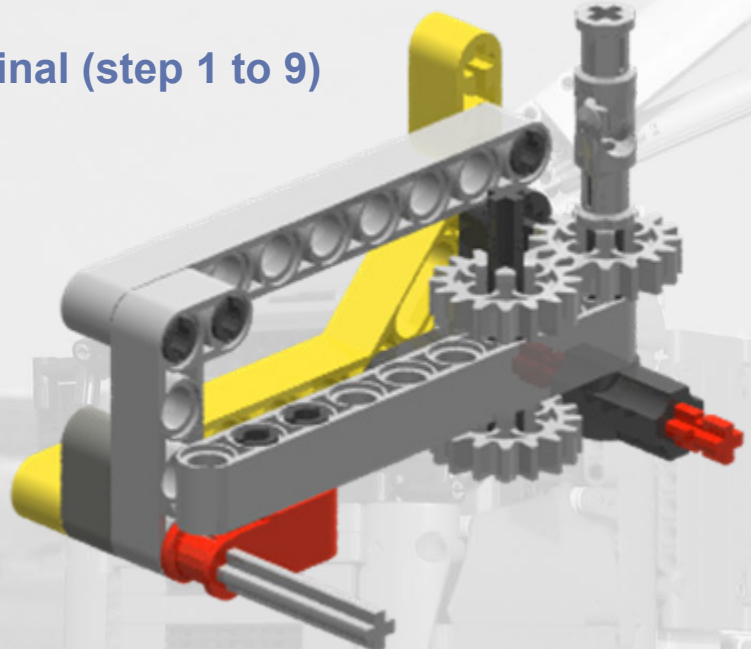

This modification does consists of 2 separate changes:
a) book-3, page 72 to 77, step 1 to 3, 8, 9, 11 and 15
b) book-4, page 7 (step 15) and page 19 (step 165)

Modification: Book-3, page 72, replace step 1 to 3, 8, 9, 11 and 15 with:



Step 1



Step 2



Step 3



Mod-2: Relocation 24th clutch gear on 2nd crane arm section (2)

Step 4 to 7 (all unchanged)

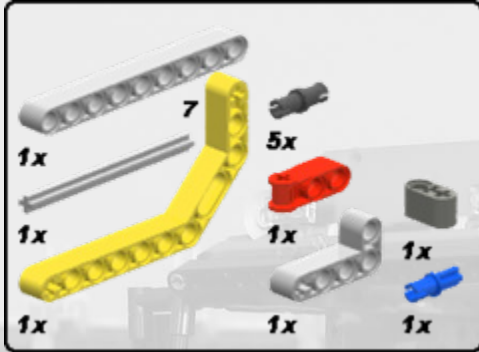

Step 8

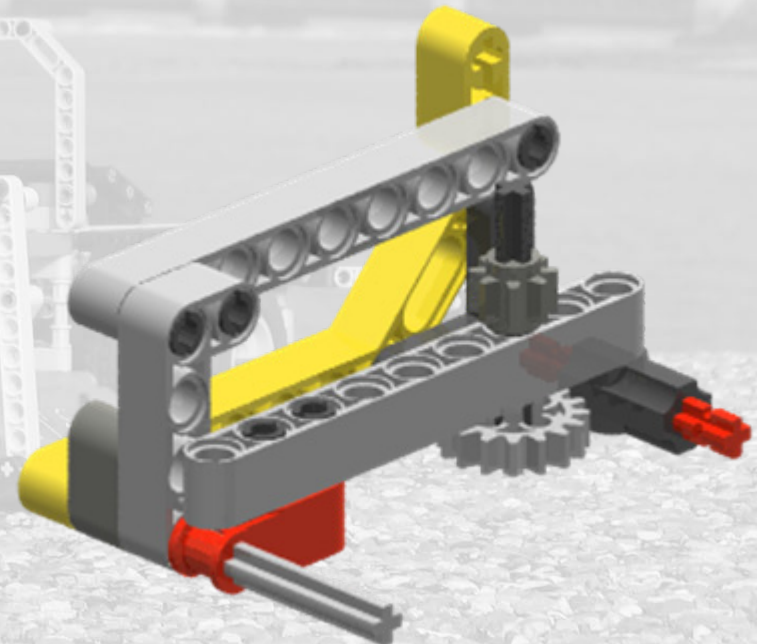
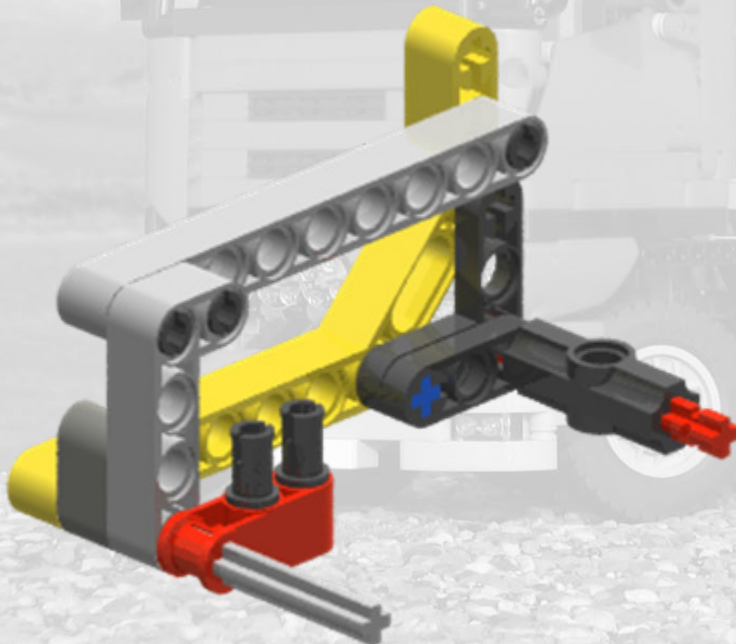
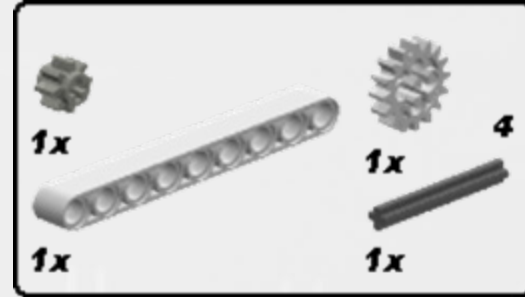

Mod-2: Relocation 24th clutch gear on 2nd crane arm section (3)

Step 9



Step 11a

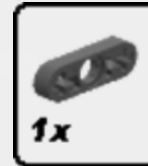

For clarity step-10 (unchanged) is not visible.

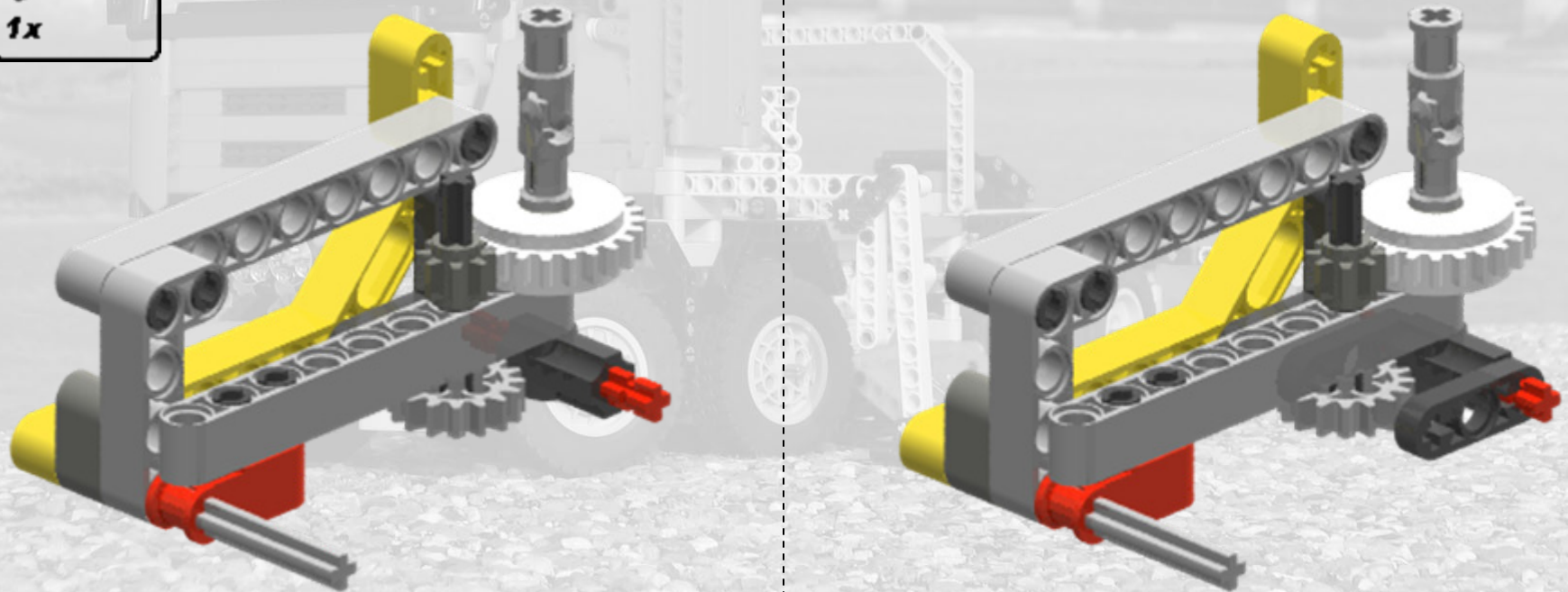

Mod-2: Relocation 24th clutch gear on 2nd crane arm section (4)

Step 11b



When ready with this step:
a) apply step 10,
b) continue with step 12

Step 12 to 14 (all unchanged)

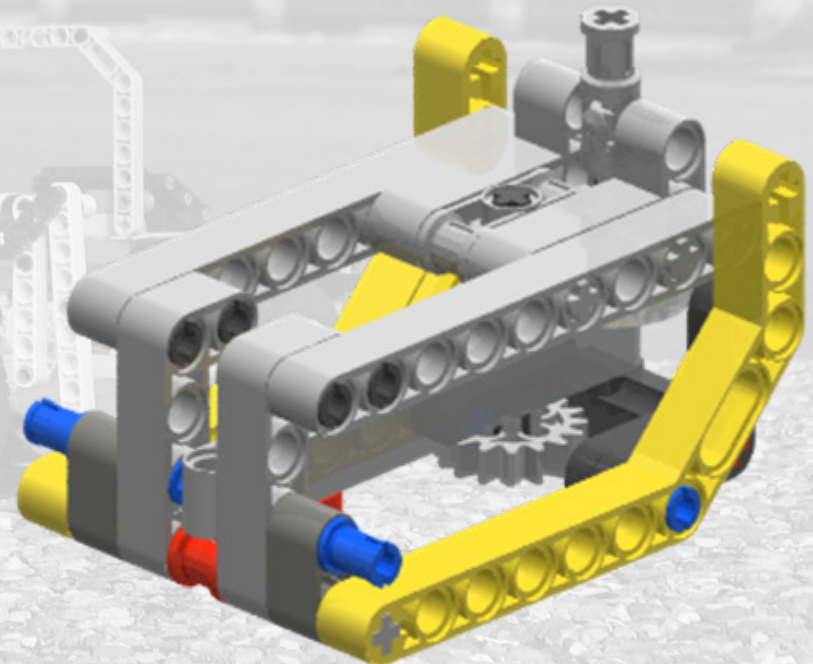
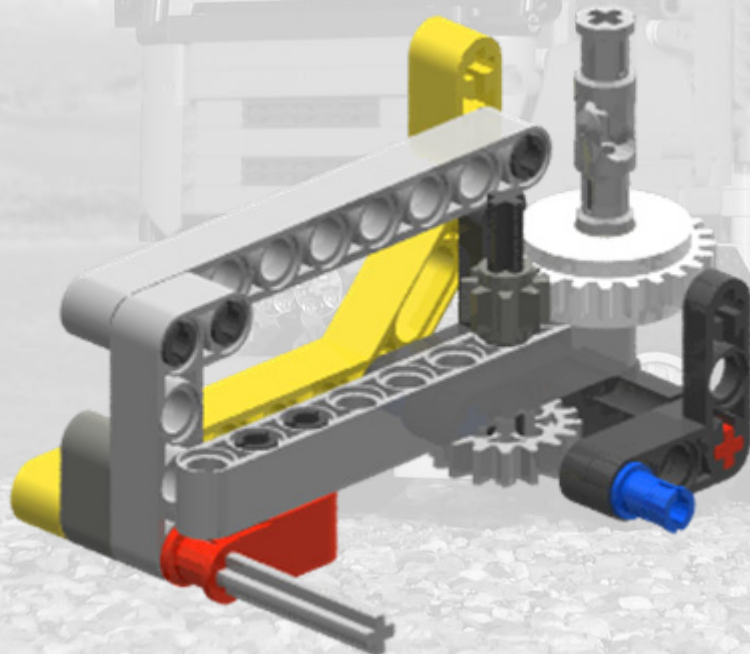
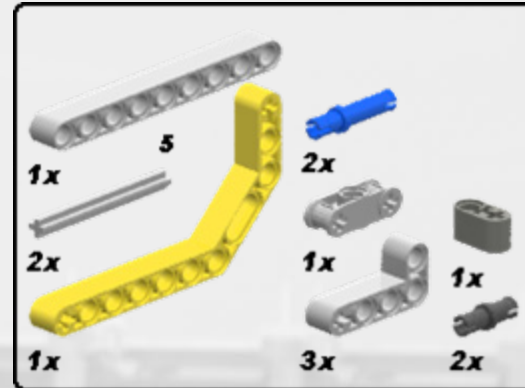

Mod-2: Relocation 24th clutch gear on 2nd crane arm section (5)

Last step 15

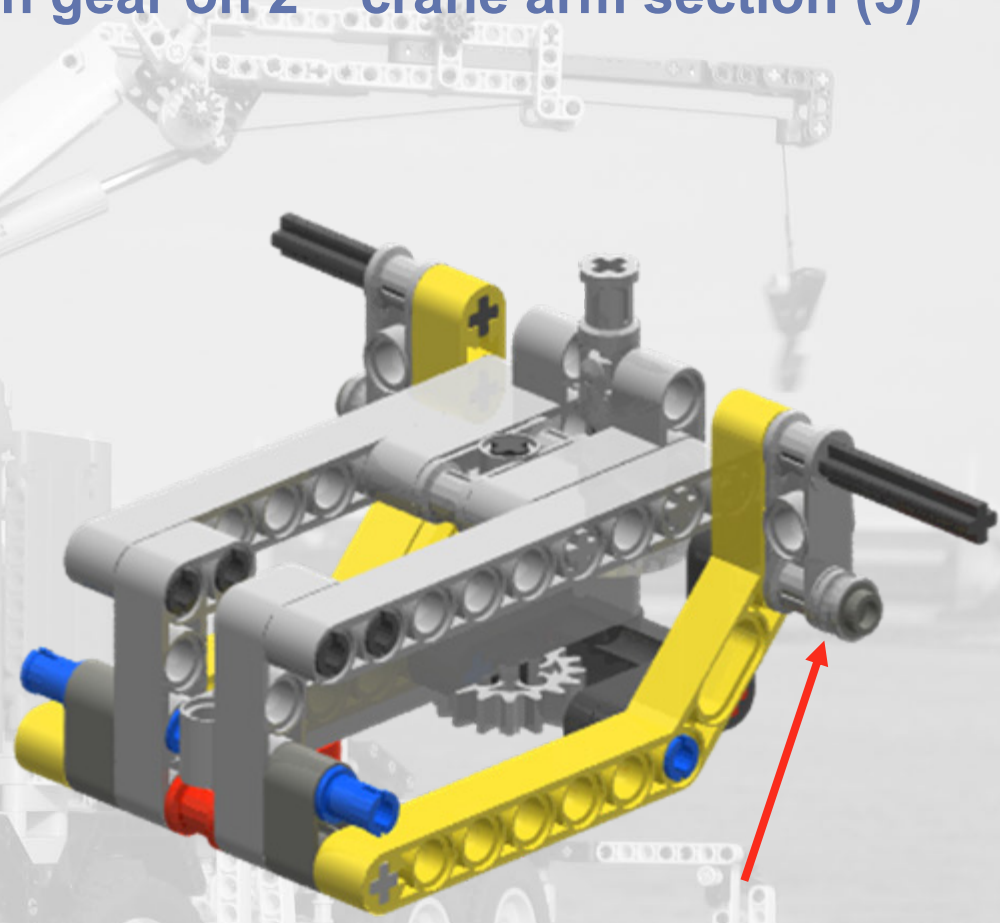
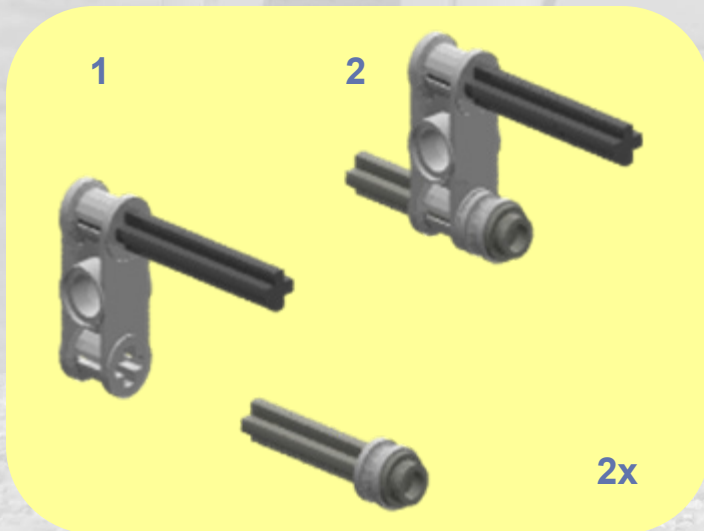

When ready with this step, continue with step 16



Mod-2: Relocation 24th clutch gear on 2nd crane arm section (6)

Modification: Book-4, replace:

Reason for this modification is to assure that the 2nd section of the crane arm will fold and unfold with the original 'speed'.

Page 7, step 15 with:

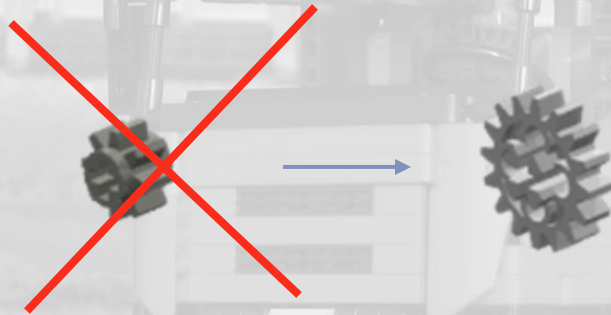

Replace 8th tooth gear with 16th tooth gear

Page 19, step 165 with:

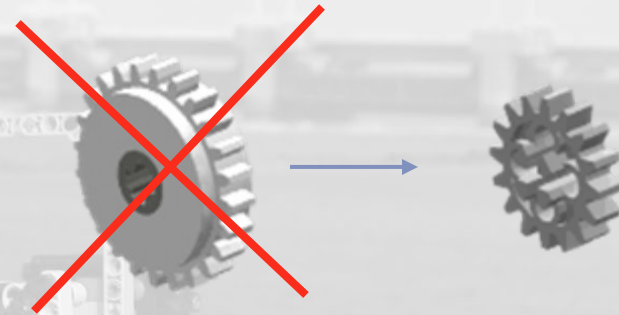

Replace 24th tooth clutch gear with 12th tooth gear

Mod-3: Prevent 'walking axle' & 12th tooth gear 'crunching'

Original

Modification

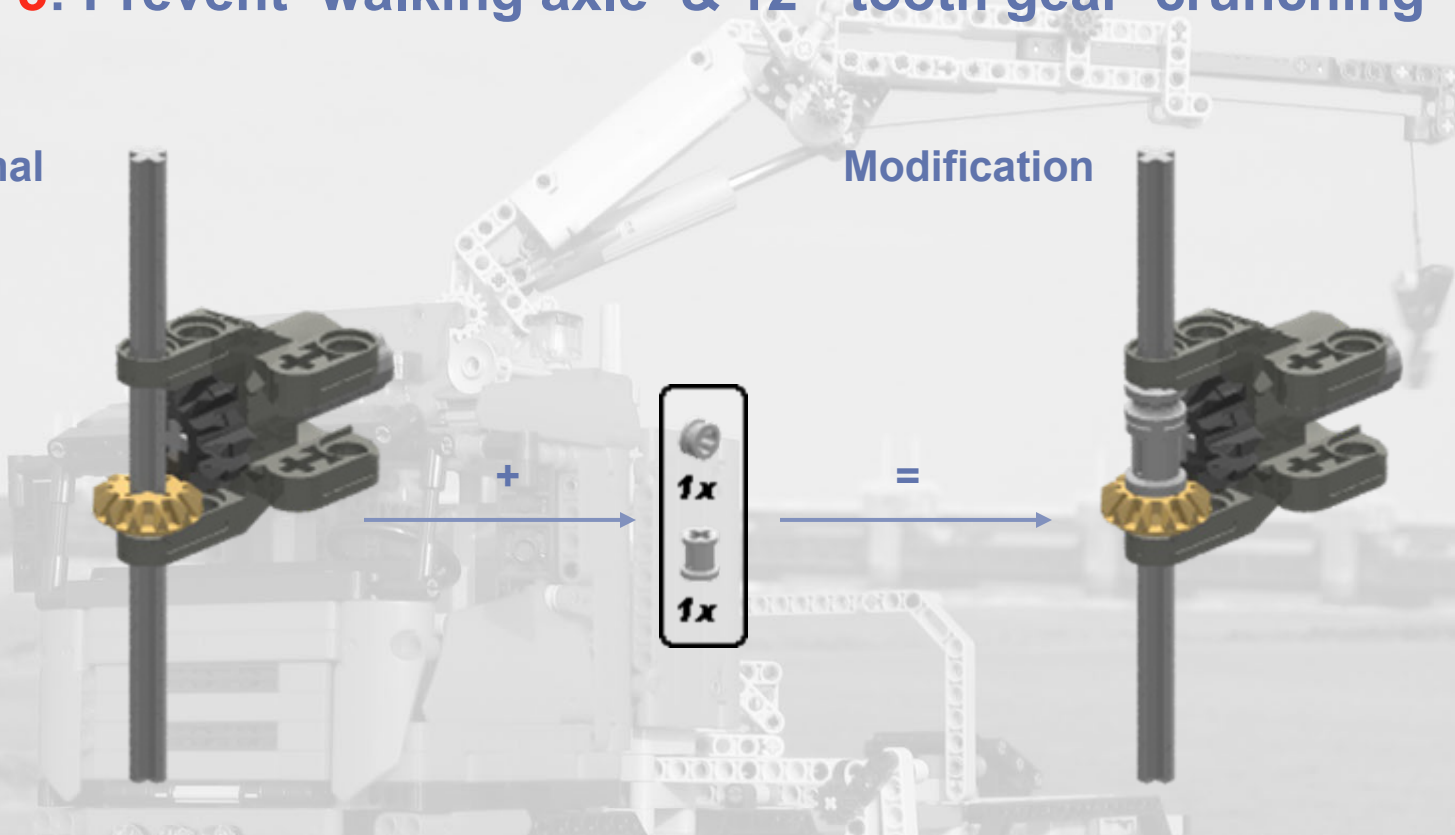

Apply this correction for every '12th tooth bevel gear with PF Linear Actuator bracket' combination:

- 1) Book-1, page 12, step 5
- 2) Book-1, page 15, step 4 (and apply modification 4 as well !)
- 3) Book-1, page 23, step 8
- 4) Book-4, page 2, step 4
- 5) Book-4, page 13, step 4

Remark: of course do not change the original axle length in all these steps !



Improved playability modifications:

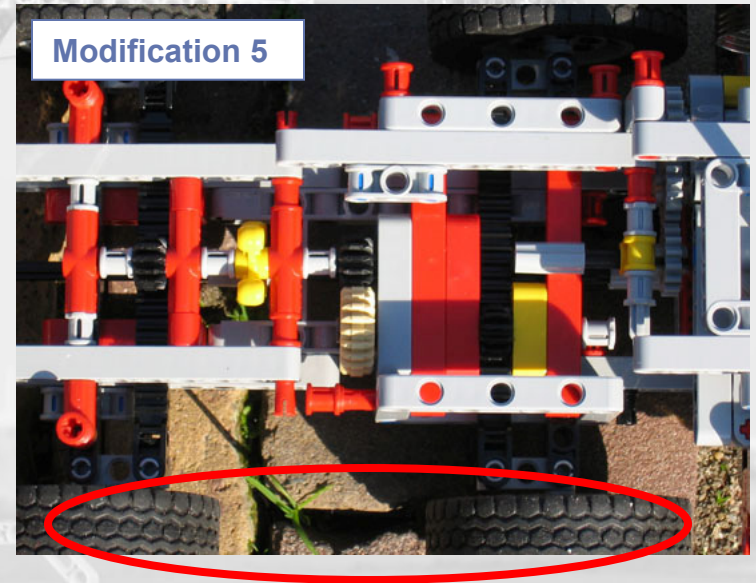
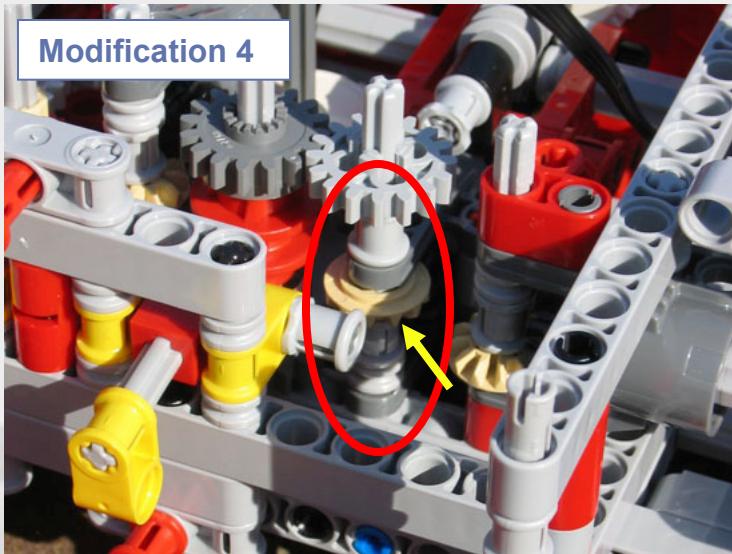

Mod-4: Correction of reverse outrigger movement

Original

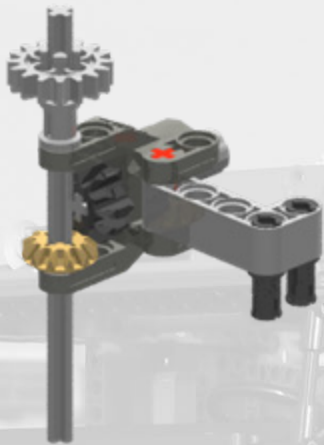

Apply this correction to the outrigger movement, so that no switch moment of the XL motor is necessary when:
a) outriggers moves out and crane arm unfolds.
b) outriggers moves in and crane arm folds.

See book-1, page 15 & 16, step 4 & 5

Modification

Page 15, step 3

Page 15, replace step 4

Continue
Page 16,
step 5

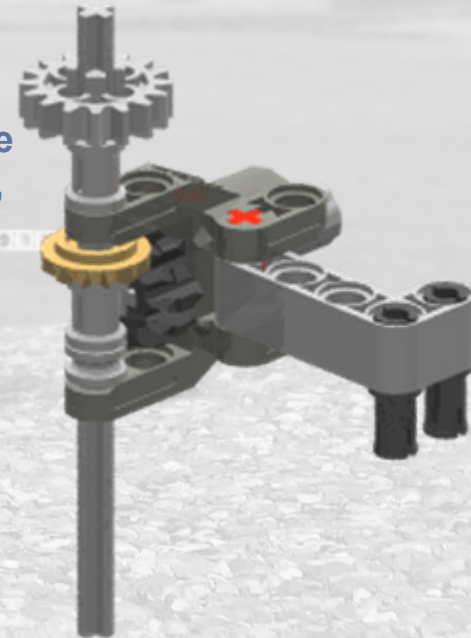
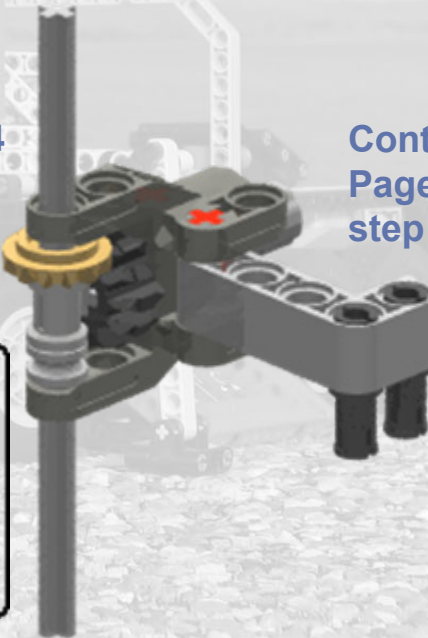
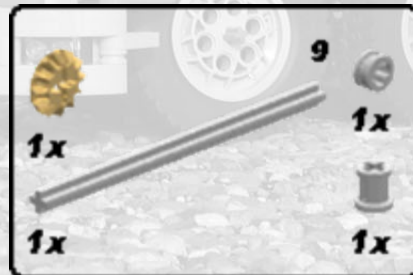
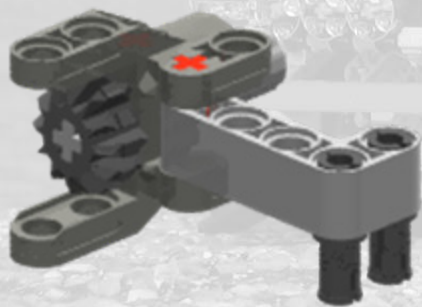

Mod-5: Clarification precisely 'in-line' steering 1st and 2nd wheels

Original

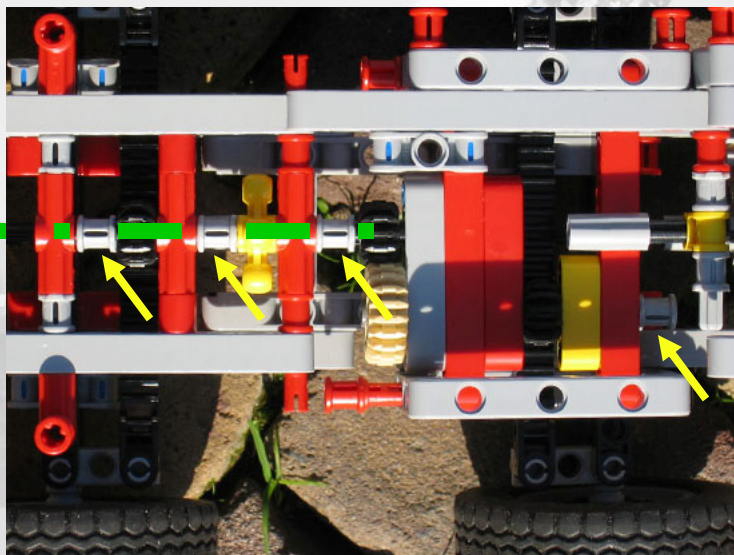

See book-1, page 67, step 60

Technical explanation picture, not based on the 8258 Crane Truck

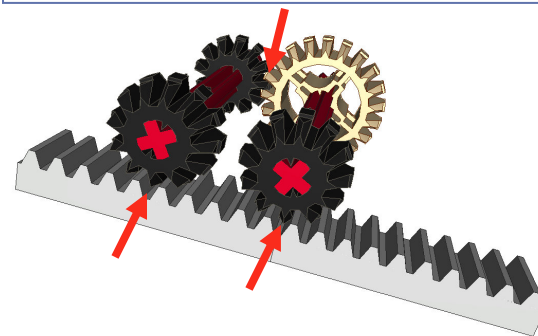

Modification

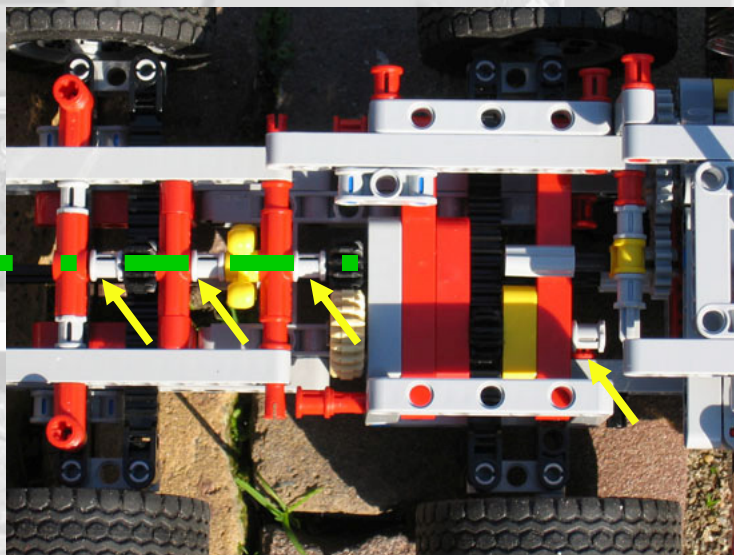

Although the 'in-line' mismatch between the 1st and 2nd steered wheels is minimal, it could be overcome when:

The axle 10L of the 1st wheel (see **green dotted line**) is NOT horizontal mounted, but 1 tooth clockwise (forward drive view). This is clearly seen at the position of the technic bushes.

Remark: of course, both 1st and 2nd wheels must be precisely in forward drive position when applying this modification.



Mod-6: Correction of lifting eye of extendable crane arm

Original



Correction of lifting eye of the crane arm, which will hinder the hook to be locked properly when fully reeled.
Actually, the crane truck is correctly constructed, but the sub-model of extendable crane arm has a fault in the building instructions.
The modification is just a 90 degree turn of the Technic axle joiner perpendicular.

See book-4, page 31, step 5

Modification

Book-4, page 31, replace step 5

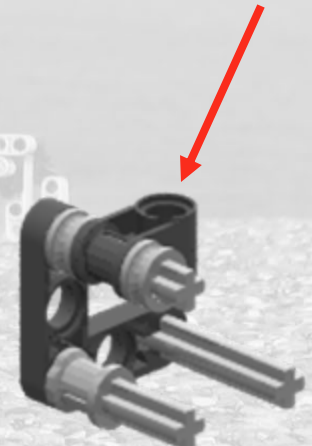

Appearance modifications:

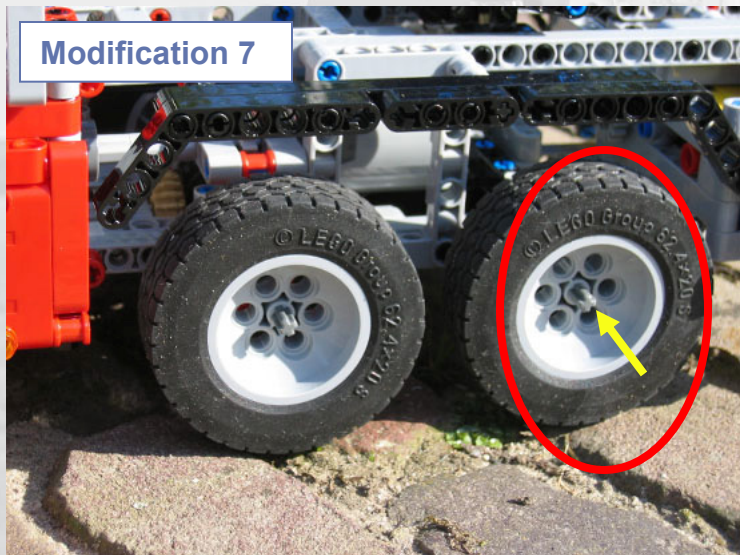

Mod-7: Correction of last wheel's axle length (1)

Original



See book-2, page 21 & 22, step 14 & 15

Modification

Step 1

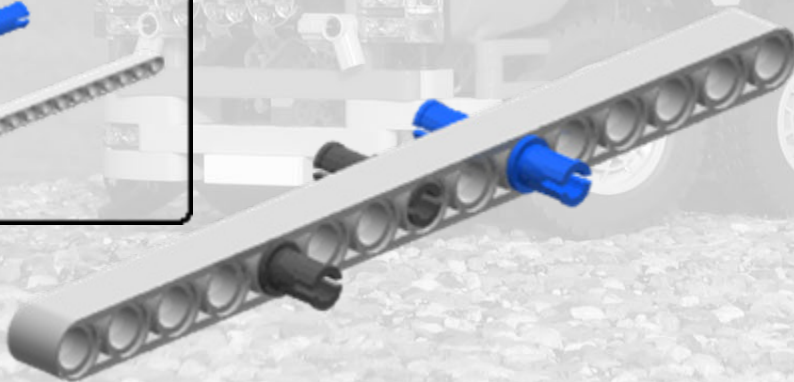
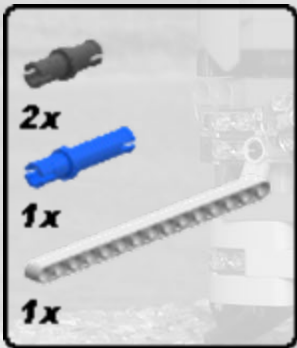

Step 2

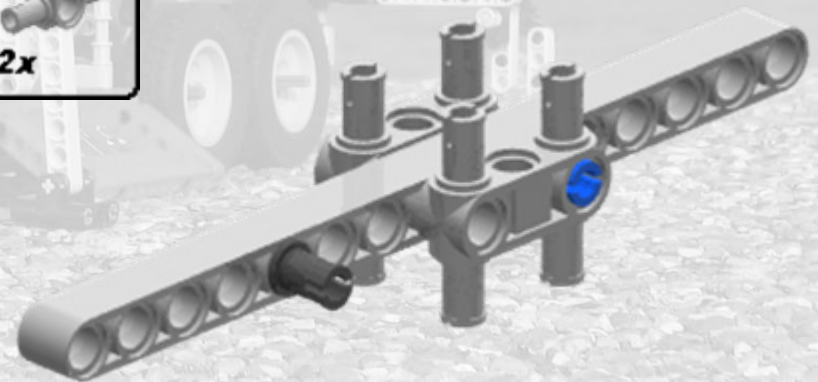
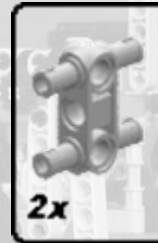

Mod-8: Steered wheels with short axles

Original

Modification

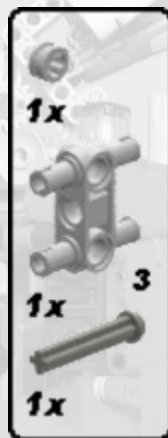

Step 1

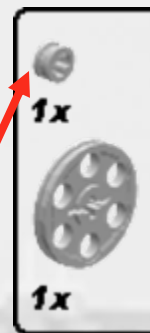

Step 2

Important: This Crane Truck set uses a NEW wheel 62.4 x 20 S (type 2) with short axle-hole ! An 'old' wheel type 1 can be used; if so, don't mount technic 'bush 1/2 smooth' in step 2 !



Step 3

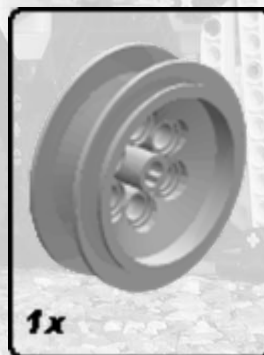

Last step 4

Tip: push pins in wheel first

Repeat 4 times for all steered wheels

